



GlobalGROUP
ISO 9001:2008



039

Online UPS

SI800 Series

1KVA~10KVA



- True on-line dual conversion design
- Sine wave pulse width modulation (SPWM)
- IGBT inverter design
- Wide Input voltage window
- True sine wave output with less than 3% THD
- Extendable backup time
- Generator compatible
- Cold start
- EMI/RFI filter
- Load/battery capacity display
- Overload, on-line, battery status LED/LCD display
- Advanced Battery Management
- Zero transfer time
- RS232
- Optional SNMP card

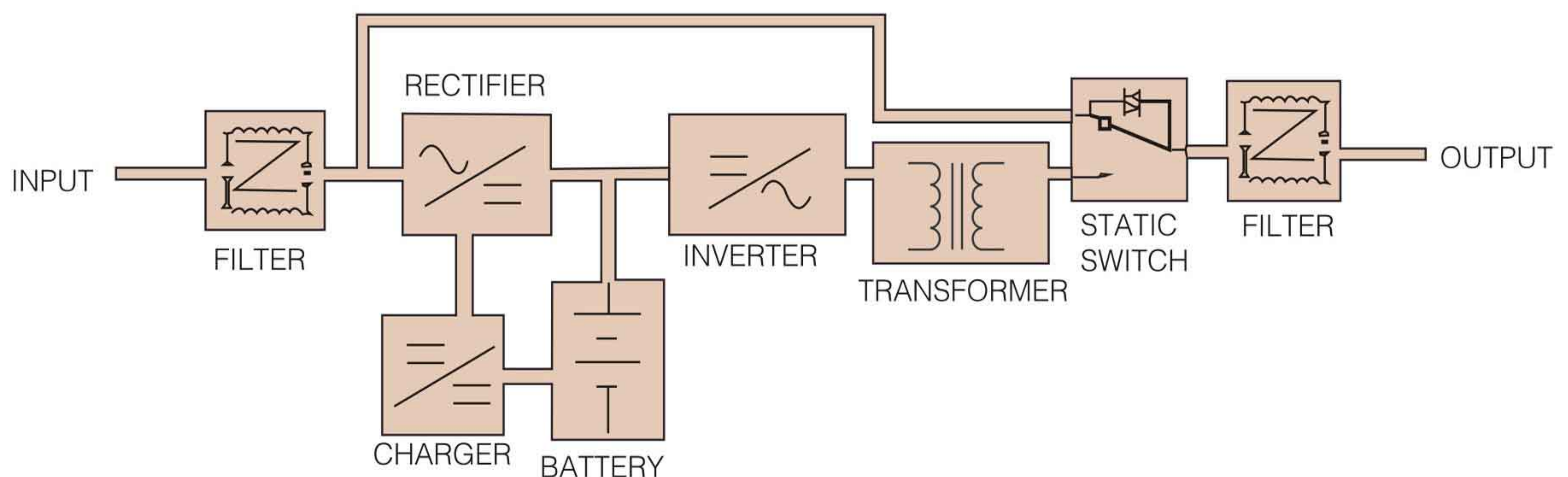



- ① RS232
- ② Air Breaker
- ③ Fan
- ④ Terminal Block
- ⑤ Wiring Holes

Ideal applications
 Data processing center, computing center, ISP, banking, securities, ISP, communications, taxation, medical service

Specifications										
Model	SI801	SI802	SI803	SI804	SI806	SI808	SI810	SI815	SI820	SI830
Capacity	1KVA	2KVA	3KVA	4KVA	6KVA	8KVA	10KVA	15KVA	20KVA	30KVA
Real Power Rating	800W	1600W	2400W	3200W	4800W	6400W	8000W	12000W	16000W	24000W
Input										
Voltage Range	220VAC ± 25% 380VAC ± 20%									
Frequency	50/60Hz ± 5%									
Phase	Single Phase +N / Three Phases +N									
Output										
Waveform	True Sine Wave									
Voltage Range	220VAC ± 1%									
Frequency	50/60Hz ± 0.5%									
THD	<3%(Linear Load)									
Short Circuit Protection	Current Limitation, Shutdown Automatically									
Overload Capability	Overload(110%~150%), Transfer to Bypass after 20s, Automatically Recover when the Load Comes back to Normal.									
Battery										
Type	Sealed Lead-Acid, Maintenance-Free									
DC	48VDC	48VDC(192V Optional)				192VDC				
Charge Current	5.0A									
Charge Time	90% Capacity after 8 Hours									
System										
Control Technology	SPWM									
Overload	125% for 1Min 150% for 1s									
Transfer Time	0ms									
Efficiency	>85%									
Display										
LCD	Operating Mode, I/P and O/P Voltage, I/P and O/P Frequency, Battery Voltage, Load Percentage, UPS Internal Temperature									
LED	Low Battery, Online, Inverter, Bypass, Abnormal									
Communication	RS232									
Monitoring Function	1.Power 2. UPS Shutdown 3.Monitor UPS Status 4. UPS Self-test 5.Auto-save Files									
Protection	Short circuit, Over-temp, Battery Low, Output Low, Surge									
Audible Noise	<60db(1 Meter)									
Environment										
Temperature	0~40°C									
Humidity	0%~95%									
Net Weight (No Battery)	35kg	57kg	68kg	62kg	66kg	100kg	110kg	200kg	245kg	300kg
Dimension(W×D×H)mm	210 × 490 × 500	210 × 580 × 540		230 × 540 × 570		305 × 585 × 870		380 × 700 × 980	430 × 810 × 1100	

◆ All specifications subject to change without notice.
 ◆ Custom-made specifications are acceptable.